

Figure 1. ATV approaches the ISS



Automated Transfer Vehicle (ATV) Structural and Thermal Model Testing at ESTEC

P. Amadiou, G. Beckwith, B. Dore

ATV Project, ESA Directorate of Manned Spaceflight and Microgravity,
Les Mureaux, France

J.P. Bouchery

EADS Launch Vehicles, Space Programme Directorate, ATV Programme,
Les Mureaux, France

V. Pery

EADS Launch Vehicles, Systems Design and Tests Directorate,
Systems Tests Department, Les Mureaux, France

ATV description

ATV capabilities

The Automated Transfer Vehicle (ATV) being developed by ESA is an unmanned vehicle that can be configured to provide the International Space Station (ISS) with up to 5500 kg of dry supplies (e.g. hardware, food and clothes) and liquid and gas supplies (up to 840 kg of water; up to 100 kg of gases (air, nitrogen, oxygen); up to 860 kg of refuelling propellant). ATV can provide propulsion support to the ISS by using up to 4700 kg of propellant. The total net payload is estimated to be at least 7500 kg. Finally, ATV can also remove up to 6500 kg of waste from the Station.

- the Equipped Propulsion Bay (EPB), which accommodates most of the Propulsion and Reboost Subsystem (some thrusters are also located on the forward part of the ICC);
- the Equipped Avionics Bay (EAB), which accommodates most of the avionics equipment (some avionics items such as rendezvous sensors are located in the ICC and EPB);
- the Solar Generation System (SGS), which includes four 4-panel deployable solar wings, each with its own drive mechanism.

The ICC accommodates all cargo apart from the reboost propellant (carried in the spacecraft) and consists of:

- the Equipped Pressurised Module (EPM), which accommodates dry cargo in dedicated payload racks. ISS waste is carried for the destructive reentry part of the ATV mission;
- the Equipped External Bay (EEB), which is an unpressurised assembly to house water, gas and refuelling propellant tanks;
- the Russian Docking System (RDS), which provides capture and release for docking with and departure from the ISS. Several RDS models, including for the first ATV, are being provided by Russia as a barter for the European Data Management System that is currently operating in the Station's Zvezda Russian Service Module.

The ICC and SC are protected by the external Meteoroid and Debris Protection System (MDPS) shield.

The ATV Structural and Thermal Model (STM) test campaign began at the ESTEC Test Centre in October 2001. ATV's capabilities, mission, configuration and development logic are outlined. The STM Test Campaign and test objectives are then detailed. Some special requirements imposed by ATV's size are described. The main test results and lessons learned are summarised.

At least eight ATV flights to the ISS are planned as part of the European contribution to supporting ISS operations (Fig. 1).

ATV configuration

The ATV vehicle is composed of two elements (Fig. 2): the spacecraft (SC; including solar array) and Integrated Cargo Carrier (ICC).

The ATV spacecraft comprises:

- the Separation and Distancing Module (SDM), which provides the mechanical interface with Ariane-5 and ATV's separation and distancing from the launcher;

ATV development logic and main system models

The ATV flight segment assembly, integration

Figure 2. ATV subassemblies and dimensions

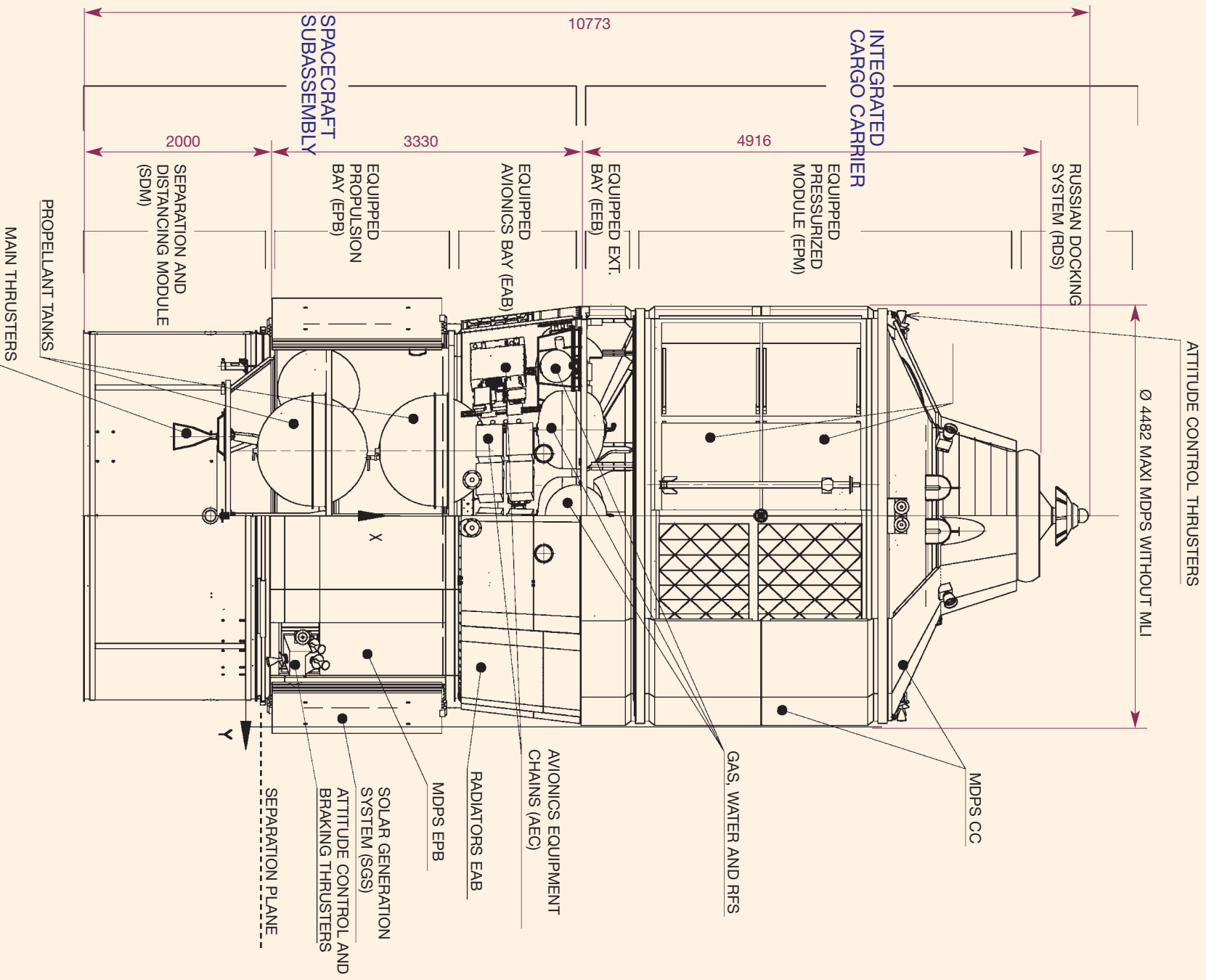

and verification during Phase-C/D uses three system-level models: STM, Electrical Test Model (ETM) and Proto-Flight Model (PFM).

The STM is being used for environmental tests in the ESTEC Test Centre. After these tests, the SC will be subjected to static tests at Contraves (CH). The ICC external bay will be subjected to further dynamic and static tests (together with a flight-standard pressurised module). The STM pressurised module will be refurbished at Alenia (I) and eventually used for crew training at the European Astronaut Centre in Cologne (D).

The ETM is being used for functional qualification testing of the ATV and for a first set of vehicle/ground segment compatibility tests. After initial integration and electrical testing of the EAB ETM at Astrium SAS (F), the full ATV ETM (including the ETM models of the avionic equipment in the ICC and EPB) will be integrated at EADS Launch Vehicles.

The PFM, now named 'Jules Verne', will be subjected to the following environmental and functional tests:

- acoustic
- electromagnetic compatibility
- solar wing deployment
- clampband release
- thermal test (EAB level)
- final set of vehicle/ground segment compatibility tests
- complementary electrical and functional qualification tests
- functional acceptance.

The ATV Flight Segment prime contractor for Phases-C/D (development, manufacture, integration of first vehicle and associated ground support equipment, as well as ATV qualification) is EADS Launch Vehicles (Les Mureaux, F). The main contractors responsible for the subsystems and/or the ATV sub-assemblies are:

- Astrium GmbH (Bremen, D), propulsion and reboost subsystem, SC integration
- Alenia Spazio (Turin, I), ICC
- Astrium SAS (Toulouse, F), avionics sub-system, EAB integration
- Contraves (Zurich, CH), SC structure sub-system
- Dutch Space (Leiden, NL), solar array.

Testing at ESTEC

The main objective of the STM test campaign is to verify the vehicle's mechanical and thermal behaviour. Since many ATV components are either derived or directly reused from previous programmes, the dynamic tests are of particular importance for confirming their

adequacy for ATV to save on delta-qualification or redesign. Another goal of the vibration tests (acoustic, sine) is to characterise the vibration environment experienced by ATV payloads in the payload racks.

The STM campaign began at the end of October 2001. Figure 3 shows the test sequence.

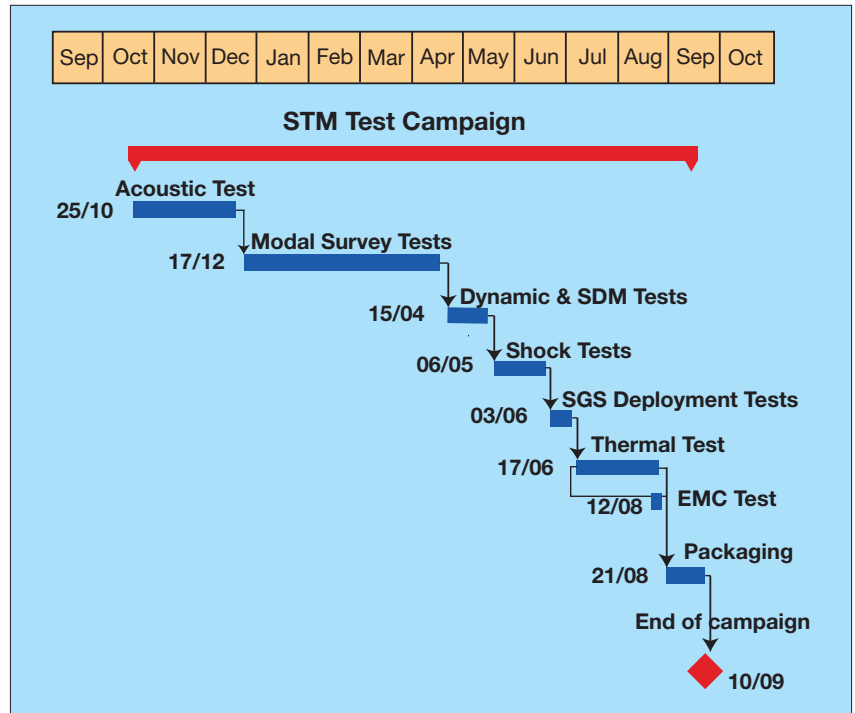

Figure 3. STM ESTEC test campaign sequence

STM representativity

The SDM model consists of a flight-representative structure, with a real clampband separation device equipped with connectors, but no distancing spring. The rest of the SC structure has only minor differences from the Flight Model. Its equipment mock-ups are dynamically and thermally representative; the stiffness at bracket interfaces is representative of the Flight Model, and there is 80% of the EPB harness and plumbing. Propulsion subsystem tanks are fillable structural mock-ups. The Thermal Control System is fully flight-representative. One solar wing is mechanically flight representative; the other three are simulated by single-panel mock-ups (identical mass and area as folded wings).

The ICC STM is dynamically representative of the Flight Model. The EPM (replaced by a special mock-up for thermal testing) structure includes a cylindrical shell and aft and forward conical parts. The EEB shows minor differences with respect to Flight Models. Racks are flight-standard. The Russian Docking System (RDS) is a mechanically and thermally representative mock-up. The ICC forward cone features a mechanical mock-up

of a rendezvous sensor, on its dedicated support. ICC gas tanks are structural models with masses representative of filled tanks. Refuelling System (RFS) kits and water tanks are fillable structural models, with dummy valves and partial plumbing.

Acoustic test

Characterisation of the vibro-acoustic response of ATV to the acoustic levels induced by the Ariane-5 launch and flight was the major requirement of the acoustic test. The final goal was to compare acoustic and random vibration levels to those specified for ATV's major components and equipment. Tests were performed in December 2001 in the Large European Acoustic Facility (LEAF) at ESTEC.

Figure 4. ATV on the Acoustic Stand in LEAF



ATV with a total mass of 15 t (low loaded configuration) was mated with the Acoustic Uncoupling Stand (AUS, Fig. 4). This adapter dynamically uncouples ATV from the ground, as well as positioning it inside LEAF's homogeneous acoustic field. Uncoupling was achieved at the top of the adapter through rubber isolator mounting pads. A dry-run test involving the AUS alone was performed a few weeks before the STM test itself.

The test sequence was:

- low-level run: overall level 141 dB for 66 s
- intermediate-level run: overall level 143 dB for 60 s
- qualification-level run: overall level 147 dB for 120 s

- low-level run (to check sensors' individual responses and to assess structural integrity after the testing): overall level 141 dB for 60 s.

Achievement of homogeneity and the specified test spectrum took less than a minute for each test run. After the first run, microphone positioning was optimised; they were moved further from the STM, outside the acoustic homogeneous field. This unusual setting was due to the STM's size, which fully occupied the LEAF acoustic homogeneous field. During the qualification-level run, nitrogen aerodynamic noise at 4 kHz in the LEAF made the target input level in this non-critical band impossible to tune precisely (higher levels than required were achieved).

All these tests were successfully performed within 4 days. Qualification random levels for equipment are in the process of being confirmed by test-result analysis.

Modal survey

The test characterised the global dynamic behaviour of the complete ATV: the main longitudinal and lateral structural eigenmodes of the ATV, and (when uncoupled) the eigenmodes of the vehicle's main components. Eigenfrequencies and shapes, effective and generalised masses and damping factors of the eigenmodes were produced by modal survey tests. These results are being used for updating the ATV mathematical model for ATV/Ariane-5 coupled load analysis.

The modal survey logic was based on two test configurations with different fluid and dry-cargo loadings. In reality, ATV will carry a wide range of payload combinations. Both configurations had a mass of around 20 t. The first used an extreme payload distribution chosen to produce maximum dynamic coupling between SC and ICC. The second was closer to a probable payload distribution for the first ATV flight, with clearly separated SC and ICC eigenmodes. The STM was interfaced with the ground by the Mechanical Interface (MIF) test adapter. Its double conical shape ensured that the high lateral eigenfrequency did not interfere with ATV's main eigenmodes during the tests.

Two methods were possible for performing the tests:

- local exciters in LEAF, with its seismic block of around 2000 t of concrete. The test principle

would then be phase resonance (direct modal identification): broad-band low-level sweeps, followed by tuned sine excitation (for identification of primary target eigenmodes), and narrow-band sweeps (for determination of modal parameters and non-linearities). Further target eigenmode information would be available through broad-band sweep analysis

- the HYDRA hydraulic shaker (3-axis excitation through eight actuators of 630 kN; four on the vertical axis, two on each lateral axis). The approach would be phase separation with broad-band low-level sweeps through sine excitation for eigenmode identification, customised broad-band sweeps and analysis to determine modal parameters and assess non-linearities. Use of HYDRA implies recording of temporal data, requiring further analysis to derive Frequency Response Functions.

The choice was driven by one HYDRA main constraint: lateral excitation along one axis results in non-negligible 3-axis excitation owing to ‘cross-talk’ effects. In order to limit risks for the success of the test, the decision was taken to use local exciters for lateral excitation in LEAF, and to use HYDRA only for longitudinal tests since this allowed higher load levels, which are useful for the estimation of damping.

Following acoustic tests, the LEAF lateral test on the first configuration started in February 2002. IABG provided four exciters: two of 2.2 kN were placed at the SC/ICC interface level and two of 7 kN were placed at the ICC upper handling ring level. The IABG data acquisition system recorded information from around 580 accelerometers and 50 strain gauges that measured SC/ICC and SC/adaptor interface force fluxes. Figure 5 shows the test set-up.

Since the MIF adapter was designed to interface with the HYDRA table, its use in LEAF required a special metal plate, bolted and torqued to the ground, onto which the MIF was fixed. To ensure proper clamping of the test specimen to LEAF’s seismic block, an epoxy layer was laid between the plate and ground. The test configuration was finally set up after a floor compliance measurement with only the MIF mated via the metal plate to the ground.

The lateral testing took 4 days, including broad-band and narrow-band sweeps, and identified all target eigenmodes. Raw results were corrected with respect to ground effects (unsymmetrical stiffness at the base of the test set-up) using forces and accelerations measured on the test floor and test adapter.



Figure 5. Lateral modal survey test set-up with ATV on MIF

A quick longitudinal test was added in LEAF using one local exciter hanging from a crane and mated with the ICC upper handling ring. Its purpose was to prepare for HYDRA runs by identifying primary longitudinal target eigenmodes.

The transfer of STM and MIF to HYDRA finally allowed the main longitudinal runs to begin (Fig. 6). Both configurations underwent longitudinal modal survey tests on HYDRA and

Figure 6. Longitudinal modal survey test set-up on HYDRA



provided satisfactory results, confirming the test predictions.

Further lateral tests were performed on HYDRA. Owing to the complex rocking motion of the table in specific frequency bands, the individual behaviours of ATV and the table proved difficult to decouple, so it was not possible to assess precisely the associated damping factors. However, those runs confirmed the eigenfrequencies of the first bending modes.

Figures 7a-c. Achieved levels for dynamic tests

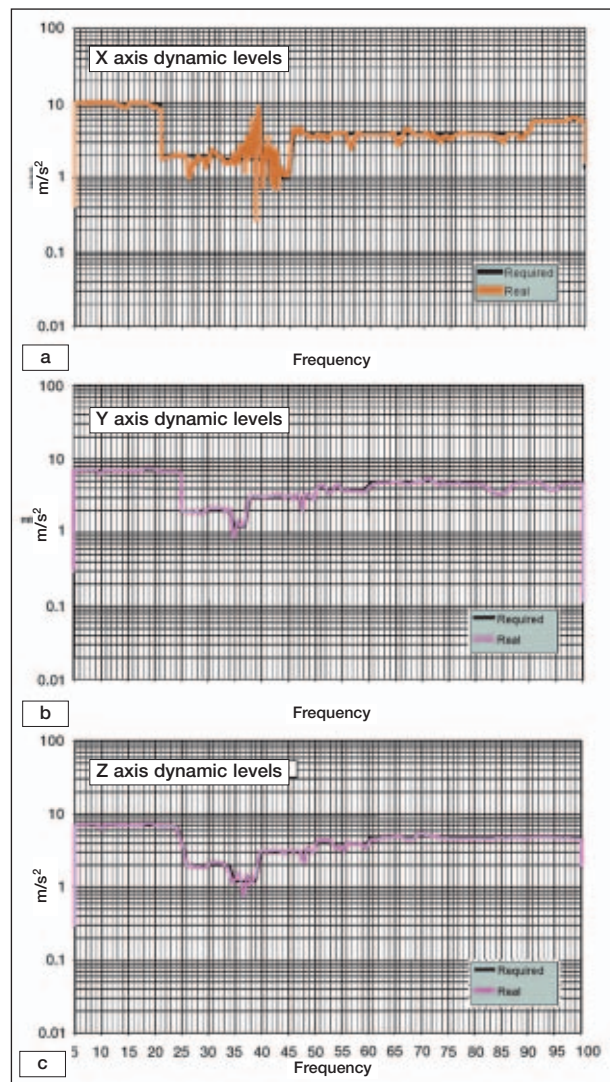

It was considered that these tests had provided sufficient information, so the test sequence was shortened and the second set of LEAF lateral testing was cancelled.

Dynamic qualification

Considering ATV's high mass (up to 20.75 t) and ESTEC's testing capabilities, the initial logic was of qualification in stages: Finite Element Model (FEM) updating after modal test, updated Ariane-5/ATV coupled-load analysis to assess dynamic qualification levels, test predictions for the SC and ICC separately, and separate dynamic tests for the SC and ICC.

However, given the good correlation between the STM FEM predictions and the modal results, and HYDRA's proven capability during modal survey tests to apply the required dynamic levels to the combined (ATV and MIF) mass of 24 t, the opportunity was taken to make use of the full STM configuration (without SDM). Thus, the new logic consisted of performing iterative runs to achieve levels as high as possible, taking into account the maximum allowable levels for ATV's main components and critical equipment, as well as the expected Ariane-5 dynamic environment. Test-result evaluation and post-test analyses would then verify that ATV can withstand the Ariane-5 environment with adequate margins.

After analysis of the modal survey results and following a thorough ATV inspection, some additional sensors were integrated into the STM. Tests along the X- (vertical) and Y- (lateral) axes were then first performed: intermediate-level runs (around 80% of flight limit levels) to record all available channels, then assessment of transfer functions for all measurement points to deduce the next run at increased levels.

Coupling between the shaker and the test article resulted in artificial damping at the eigenfrequency of the first ATV bending mode. The input levels were adapted around this eigenfrequency to obtain the correct force at the ATV interface. Interactions between the test article and the shaker table induced control difficulties, and therefore limited the input levels at specific frequencies. In this case, the finally applied levels were adjusted to reach qualification levels on heavy items such as propellant tanks.

These two first dynamic qualification tests were completed successfully.

Given the test configuration symmetry, Z-axis input levels were the same as those specified along the Y-axis. Figures 7a-c show the final applied input levels at ATV's base. Differences between the specified and achieved levels were caused by either notching or control effects. The qualification testing in three axes was considered to be successfully completed at the end of April 2002. The final Ariane-5/ATV coupled-load analysis aims to confirm the input levels used during the tests.

Thanks to HYDRA, the ATV STM is the heaviest and largest specimen ever subjected to high-

level sine vibration testing for an ESA programme.

The sine-test specifications for equipment were refined on the basis of the results of the qualification tests. In particular, qualification vibration specifications for ATV's Russian equipment, originally qualified for launch on Russian vehicles, are in the process of being confirmed. This would avoid modification of those items when used on ATV.

Mechanical qualification testing will be completed by static tests on the primary structure and by pressure integrity tests on the pressurised module.

ATV (including SDM) modal test

The 2 m-high SDM cylindrical adapter was developed for ATV to interface directly with Ariane-5's 3936 mm diameter. The SDM adapter includes a clampband separation system that was developed specially for ATV's large diameter. This adapter uses the new 'clamp ring separation system' technology, which offers the advantage of generating low shock levels.

In order to assess the influence of the adapter on ATV's global dynamic behaviour, it was decided to perform additional characterisation tests. The complete ATV launch configuration (including SDM) was vibration-tested on HYDRA in the longitudinal and lateral directions (low levels, X and Y excitations; Fig. 8). The tests verified the compliance of ATV's (including SDM) first lateral eigenfrequency with Ariane-5's requirements (i.e. this eigenfrequency should be high enough to avoid influencing launcher behaviour).

Shock tests

Shock tests involved a complete ATV/SDM configuration hoisted in the HYDRA Preparation Area (Fig. 9). The first shock test (the 'Shogun' test) dealt with the ATV external shock from the jettisoning of Ariane's fairing. A dedicated pyrotechnic device (Shogun) was provided by Arianespace to generate these representative shock levels at the SDM interface. This device was made of a pyrotechnic linear cord charge inside a weakened aluminium structure (3936 mm diameter). The shock wave was generated by the expansion of the tube causing a controlled rupture of the lower flange screw section. A spacer (a 260 mm-diameter cylinder developed for ATV ground integration operations) provided the interface between the SDM and Shogun, and was intended to create the proper shock level at SDM's lower interface.



Figure 8. ATV (with SDM) modal tests on HYDRA



Figure 9. ATV shock test set-up in the HYDRA preparation area

A dry-run at the end of March 2002 demonstrated that Shogun produced the required shock levels. The STM Shogun test was successfully completed at the end of May.

The second shock test concerned the clampband release. The Shogun and spacer were removed, and SDM was held to prevent its lower half falling after release. The test used shock sensors and two high-speed cameras (1000 frames/s). The clampband was successfully released after exposure to the Shogun shock.

The shock transfer functions from the bottom of the ATV to the most critical equipment were measured. It was verified that the shock at the base of ICC produced negligible levels for this module's equipment. The shock levels on the other equipment will be derived by post-test

deployment were within specifications. Deployment was therefore demonstrated after exposure to the acoustic, shock and dynamic qualification environments.

Thermal balance test

Checking and upgrading ATV's Thermal Mathematical Model, to be used for ATV qualification, will be achieved via global thermal characterisation in vacuum of a test specimen thermally representative of ATV under dissipative and environmental thermal loads.

The semi-active Thermal Control System (TCS) is based on Active Fluidic Cooling Units (AFCUs) containing heat pipes. The verification of its performance required the characterisation of the AFCU heat rejection maximal capacity in a hot environment and of the AFCU maximal insulation in a cold environment. The thermal test also verified the thermal control algorithms and thus the capacity of this TCS subsystem to maintain the vehicle within required limits. Secondary objectives, such as identification of the heat leak sources and confirmation of the heat leak budget, and thermal characterisation of the docking system and structure under thermo-mechanical loads, were also addressed.

This was the final STM test at ESTEC, in the Large Space Simulator (LSS) between the end of July and early August 2002. Severe thermal requirements drove the ATV configuration inside LSS (Figs. 11 and 12):

- keeping the heat pipes horizontal was critical for them to work. This meant that ATV had to be vertical inside the LSS, and therefore heated from the side by the solar simulator
- the STM had to be illuminated by the solar beam to simulate the hot and cold transient and steady flight phases, and thermal cycling. The 6 m-diameter beam required replacing the EPM (pressurised, temperature-controlled module, behaving only as a thermal inertia) with a smaller mock-up
- the three sides not in direct view of the Sun had to face controllable, simulated Earth thermal fluxes. This was supplied via a structure in three planes (Figs. 11 and 12 show two). Each plane of this EASi (Earth Simulator) consisted of 15 individually heated panels. The complete assembly was mated to the LSS seismic platform through a support ring
- the aft side had to face a simulated Sun and deep space (the LSS seismic platform is uncooled). This SORSi (Solar Rear Simulator) was equipped with heaters and liquid-nitrogen circulation for the different test-phase needs.
- the Thermal Test Stand connecting the STM and LSS platform minimised the thermal



Figure 10. Solar wing under the deployment rig

analyses using these transfer functions. The main goal of the second test was to measure the shock levels at the most critical equipment interfaces. Further analysis incorporating the results of the two tests will validate the shock specifications for ATV's various elements and confirm, where necessary, the system margins.

Solar array deployment

An associated goal was assigned to the acoustic and shock tests: the application of these environments to a stowed solar array in order to verify its correct deployment. The deployment test took place following the end of shock tests with the SC horizontal (and without SDM or ICC). A rig held the wing to compensate for gravity (Fig. 10). The deployment was successful. The times for cutting the hold-down cables and for wing

fluxes between the two, as well as limiting interference with the LSS walls. This was achieved by a tubular lightweight structure with controlled thermal properties (thermal isolation, control of interface temperatures, multi-layer insulation).

As probably one of the most complex parts of the STM campaign, the thermal test also involved numerous electrical lines dedicated to:

- supplying 55 kW to more than 200 main lines for the heaters that simulated equipment power dissipation inside the STM, and for the heaters that guaranteed the thermal environment and boundary conditions for ATV or test adaptation interfaces
- acquisition of measurements from more than 800 thermocouples dedicated to measurement or control
- control of the AFCUs.

Additional activities

Some tests and measurements, though not directly associated with the environmental tests themselves but linked to operational verification, were added during the various phases of the STM test campaign. Indeed, the STM integration and test operations prefigure activities to be performed with the first Flight Model, either during its test campaign at ESTEC or during the launch campaign at Kourou, French Guiana.

Knowing the time and manpower required for each activity will allow the schedule for ground processing at Kourou to be refined. Throughout the test campaign, the large size of the ATV elements and the Mechanical Ground Support Equipment (MGSE) compared to that of the ESTEC cleanrooms led to numerous movements within the test facility. For example, tilting the SC from vertical to horizontal requires a ground area of about 6 x 9 m². Figure 13 highlights the size of the ICC container. The lessons learned in using the MGSE will help in laying out the integration and check-out area in the new S5 building at Kourou.

The STM test campaign also involved integrating ATV's major subassemblies (SC, ICC, SDM) for the first time (Fig. 14). This verified the interfaces between such large structures. Some of the techniques developed for STM will be used for Flight Model integration and operations in Europe and Kourou. For example, the AUS will be reused as an ATV integration and transfer stand.

Three operational verifications were also carried out on the SDM:

- characterising the evolution of clampband tension during the various integration

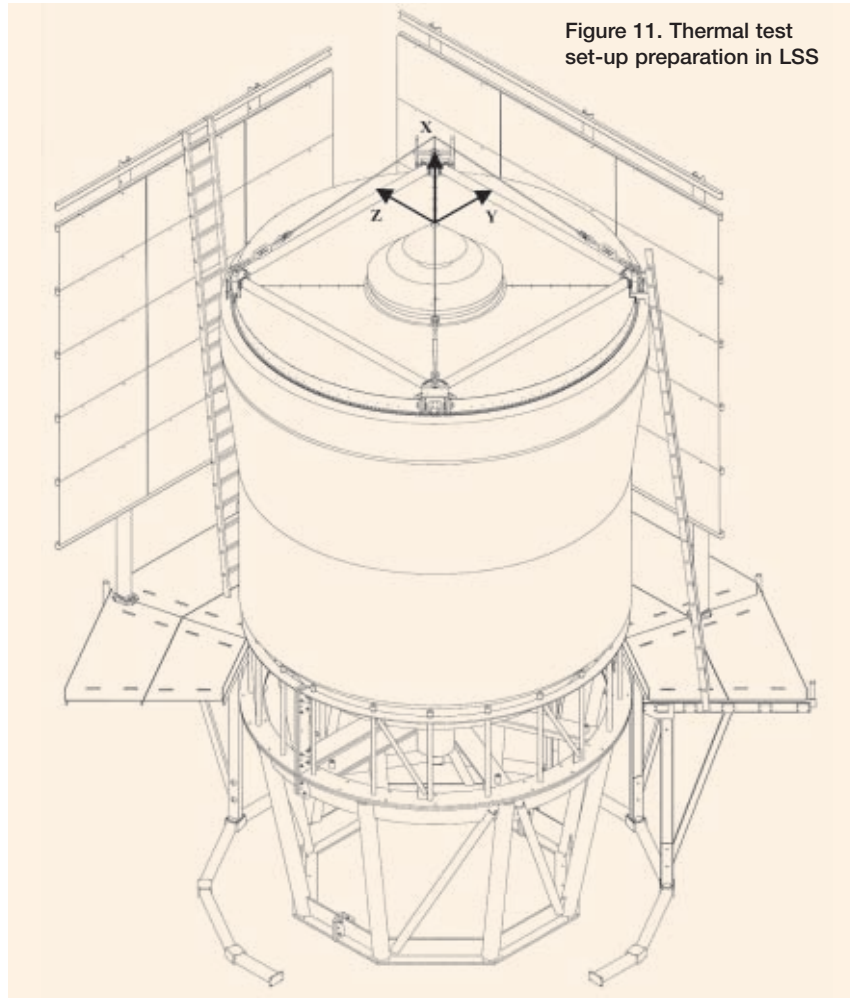

Figure 11. Thermal test set-up preparation in LSS

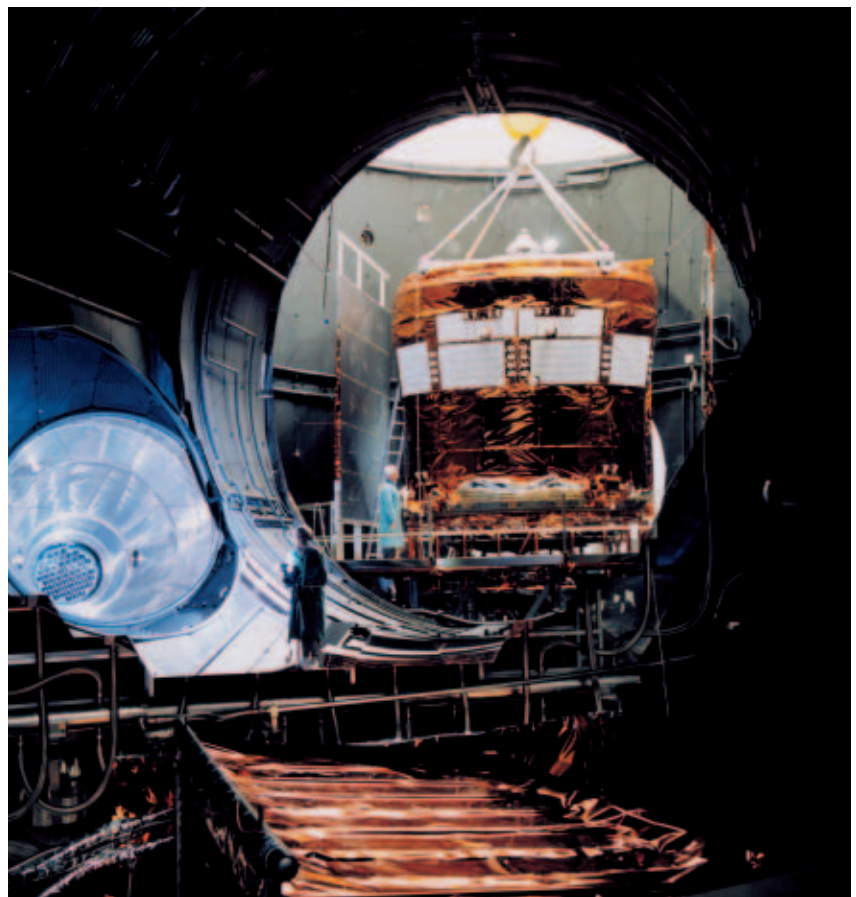

Figure 12. The ATV STM in ESTEC's LSS before thermal-balance testing



Figure 13. The ICC container is unloaded from the Beluga aircraft at Schiphol airport

operations. This tension was measured before and after the mating of the SDM with the spacer and the SC at, respectively, its lower and upper interfaces. Additional measurements were performed with and without ATV's mass on it (ATV hanging from the overhead crane). The goal was to verify the possibility of tensioning the clampband before PFM filling operations. The mathematical model was updated from the results

- measuring the geometry of SDM's lowest interface (when mated with the rest of ATV) to verify Ariane-5/ATV integration



Figure 14. Preparing for the first mechanical integration of ATV

- verifying the mating of the SDC (Separation and Distancing Cylinder, which is SDM's lower part) and the SES (SEparation System, which is SDM's upper part) when ATV is fully integrated.

The alignment of some elements of ATV Guidance Navigation and Control (GNC sensors and thrusters) is critical for the robustness of the flight control algorithms. Before and after each environmental test, the position and orientation of these elements were measured via videogrammetry in order to assess the impact of the applied environment.

Finally, a short electromagnetic (EM) test was performed using the thermal test configuration to measure the EM-shielding effectiveness of the EAB structure. The EM field was generated around the test object and specific test antennas allowed characterisation of the EM field inside the avionics bay. The results showed that the ATV structure provides the required attenuation of external EM fields.

Conclusion

The STM test campaign proved to be very intense. In addition to its own teams, EADS Launch Vehicles managed and coordinated teams from ETS (logistics, test logistics), Astrium (mechanical and fluidic operations), IABG (modal and dynamic tests), Arianespace and Intespace (shock tests) and other ATV subcontractors (Alenia, Contraves, EADS CASA, Dutch Space, APCO). ESA, as ATV customer, performed programmatic and technical monitoring. Numerous decisions had to be taken 'on the spot', making use of available materials and means. All the challenges were successfully met thanks to the efforts and constructive ideas of these teams, and the STM test campaign is expected to be completed by mid-September 2002, 2 months ahead of schedule. All involved are to be thanked for their dedication and commitment. This ESTEC campaign was the first involving ATV and all the related ground support. It offered a unique opportunity to check most of the critical mechanical operations that will be required for the flight operations in Europe and Kourou. The data gathered during this test campaign pave the way for the ATV Critical Design Review in April 2003 and for the PFM 'Jules Verne' ESTEC test campaign and Kourou operations.

Acknowledgements

The authors thank all their colleagues who, through their comments, contributed to this article.